

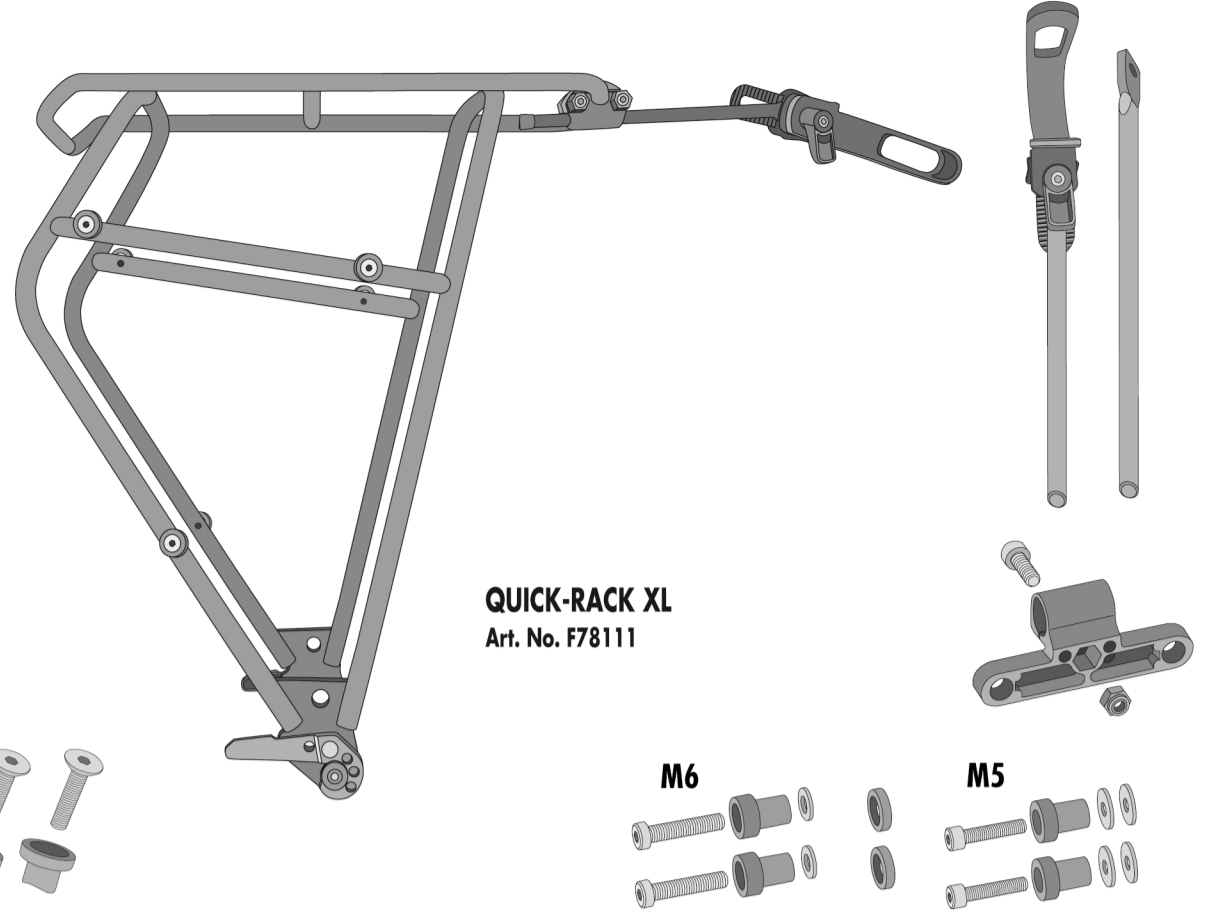

ORTLIEB Sportartikel GmbH
Rainstraße 6
91560 Germany
www.ortlieb.com

QUICK-RACK XL

- DE MONTAGEANLEITUNG
- GB ASSEMBLY INSTRUCTIONS
- FR INSTRUCTIONS DE MONTAGE
- IT ISTRUZIONI DI MONTAGGIO
- NL MONTAGE HANDLEIDING
- DK MONTERINGSVEJLEDNING
- ES INSTRUCCIONES DE MONTAJE
- SE MONTERINGSANVISNING
- NO MONTERINGSANVISNING
- FI ASENNUSOHJEET
- PL INSTRUKCJA MONTAŻU
- JP 装着方法



QUICK-RACK XL
Art. No. F78111

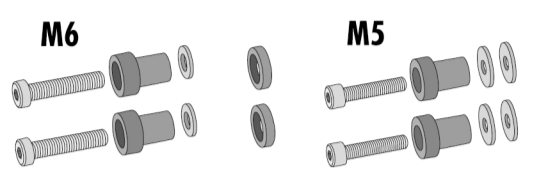
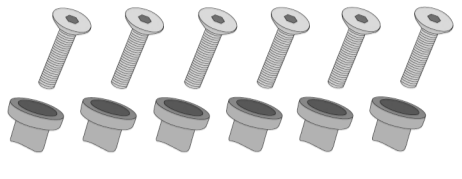

REQUIRED TOOLS

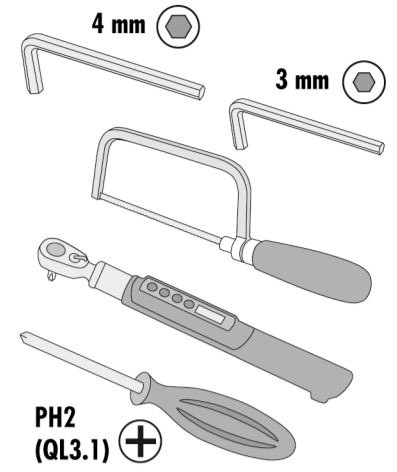

! CHECK TIRE CLEARANCE

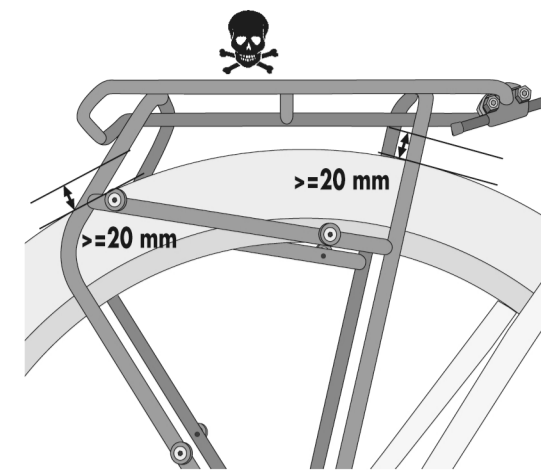

MOUNTING OPTION 1 (MO1)

THRU AXLE M6-CONNECTOR
MAX. TIRE SIZE 29" / 2.6"

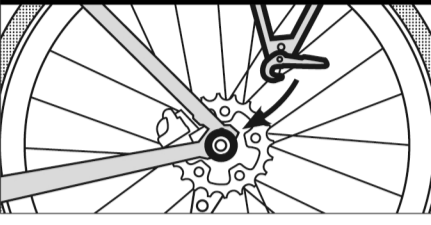

MOUNTING OPTION 2 (MO2)

DIRECT MOUNT M5/M6
MAX. TIRE SIZE 29" / 3"

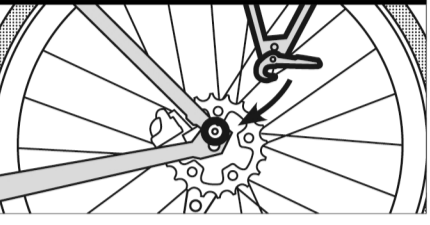

MOUNTING OPTION 3 (MO3)

QUICK RACK SEAT STAY ADAPTER
MAX. TIRE SIZE 29" / 3"

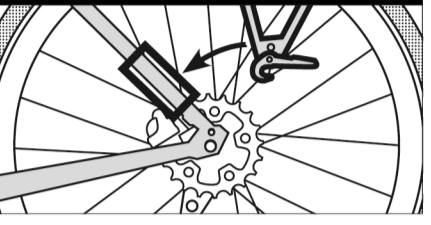

MO 1 USE ACCESSORY THRU AXLE M6-CONNECTOR

Art. No. F78112
F78113
F78114

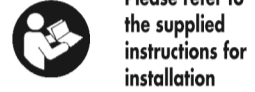

Please refer to the supplied instructions for installation

*Accessory implies not included

MO 1.1 CHECK COMPATIBILITY

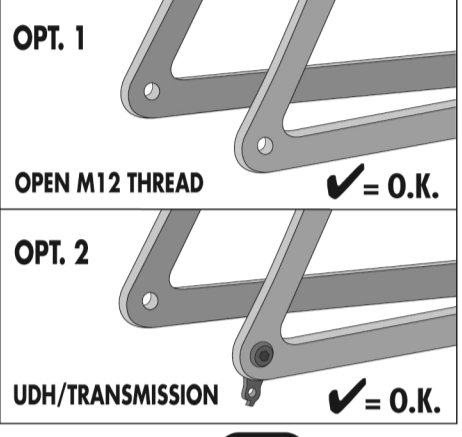

MO 1.2 MOUNTED AXLE

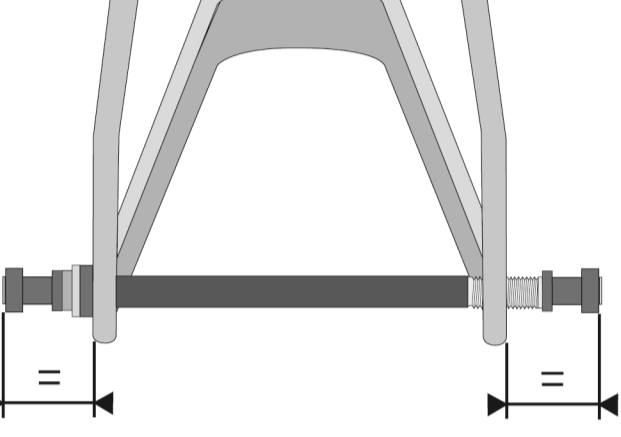

MO 2 DIRECT MOUNT M5/M6

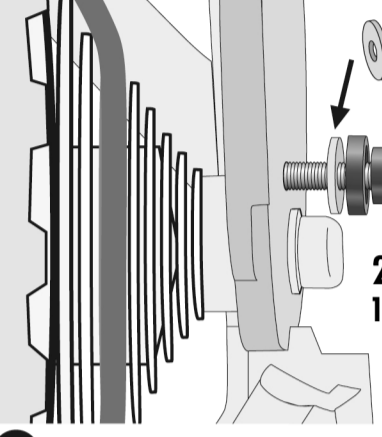

MO 2.1 CHECK COMPATIBILITY

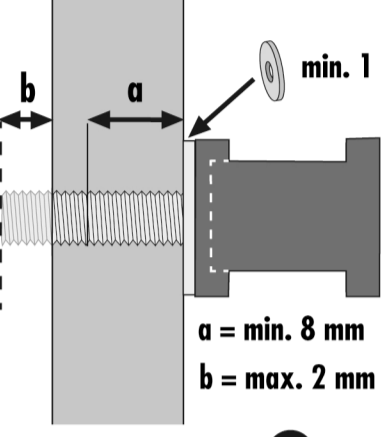

MO 2.2 COMPATIBLE FRAME WIDTH

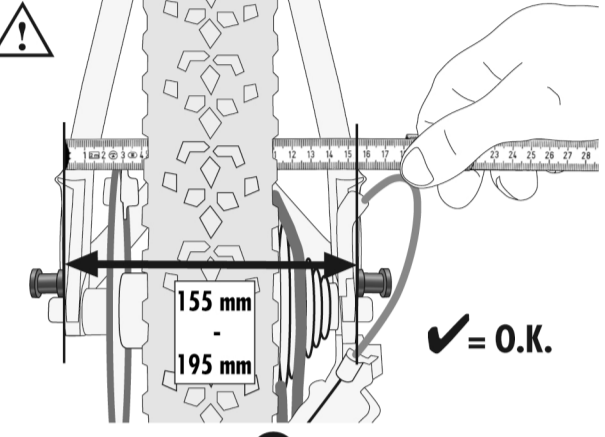

MO 2.3 CHECK LEVER CLEARANCE

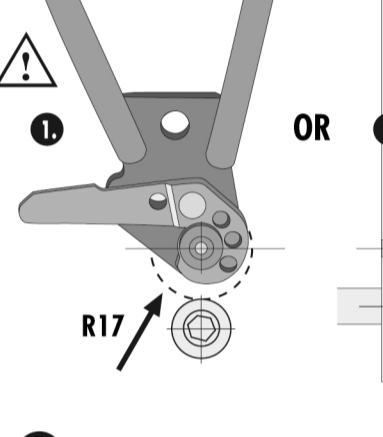

MO 3 USE ACCESSORY SEAT STAY ADAPTER

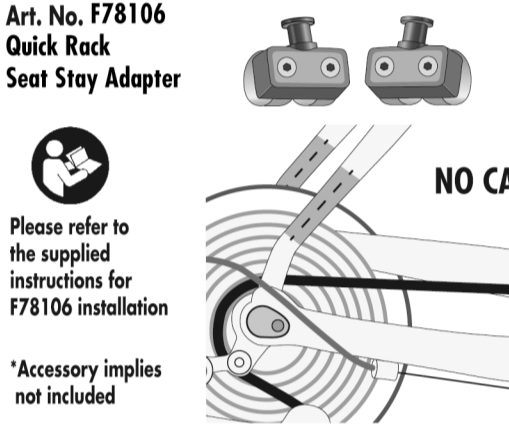

1.1 INSERT ROD

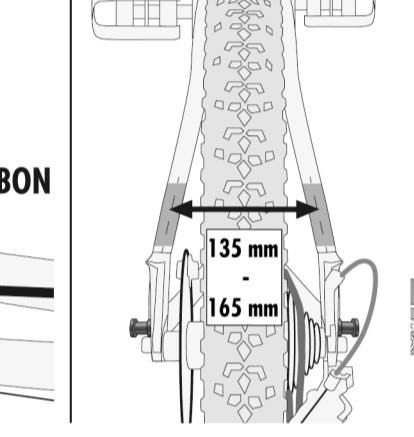

2.1 OPEN LEVER

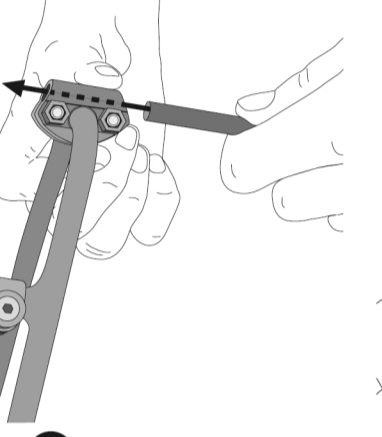

2.2 CONNECT LOWER ATTACHMENT

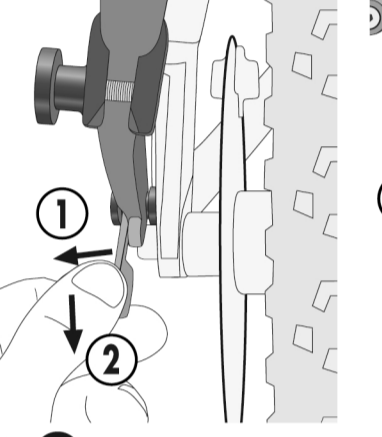

2.3 CLOSE LEVER

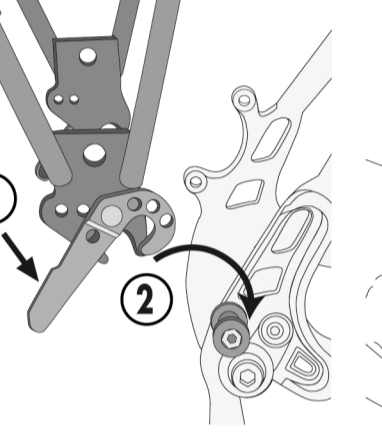

2.4 CHECK CORRECT CLOSURE

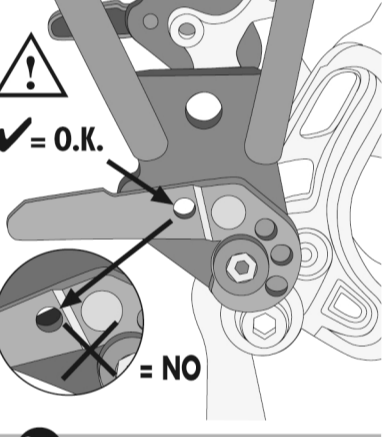

3.1 FIND UPPER ATTACHMENT POSITION

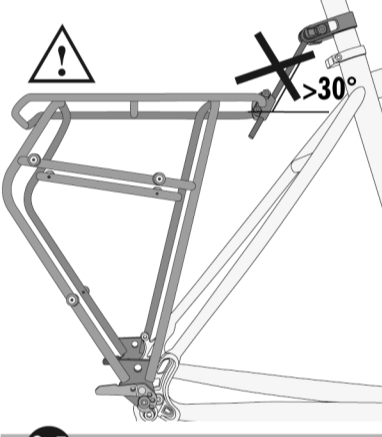

3.2 SLING STRAP AROUND

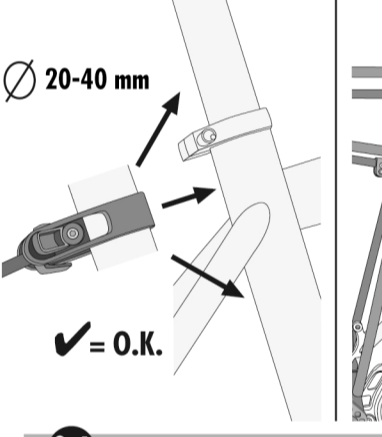

3.3 INSERT STRAP AROUND OPEN LEVER (FACING FORWARD)

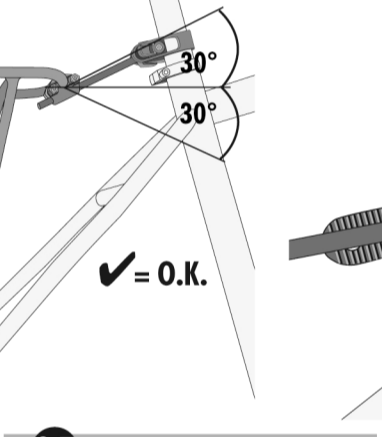

3.4 TIGHTEN STRAP

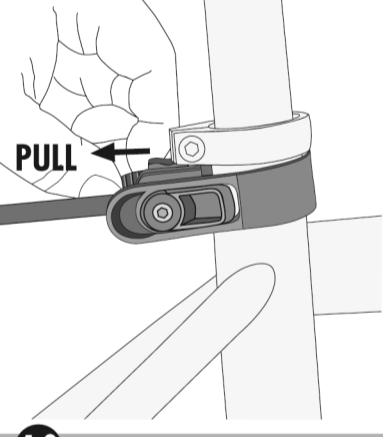

3.5 CHECK TEETH FIT

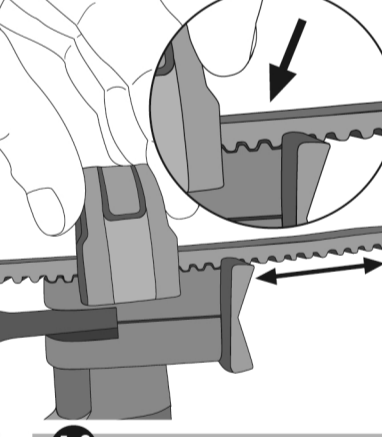

3.6 SECURE SCREW

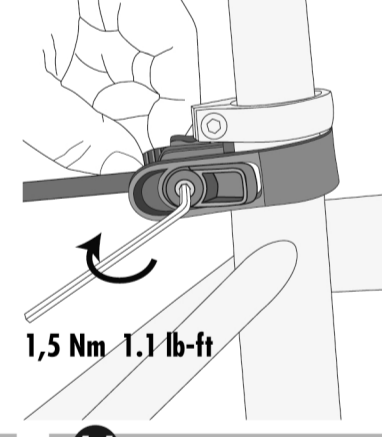

3.7 CLOSE UPPER ATTACHMENT

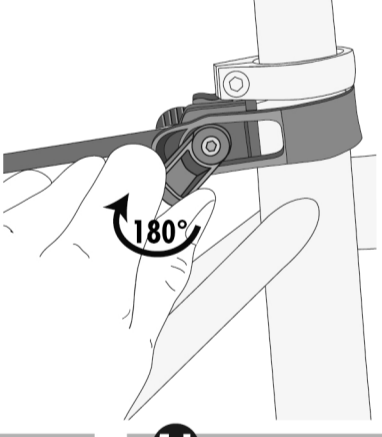

4.1 CORRECT ORIENTATION

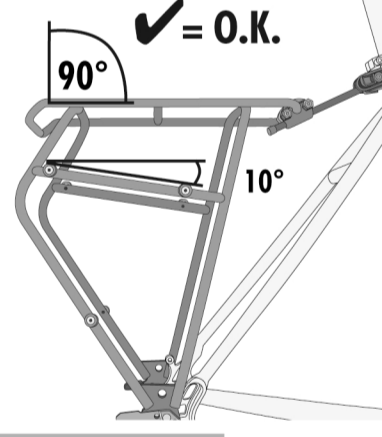

4.2 CHECK TIRE CLEARANCE

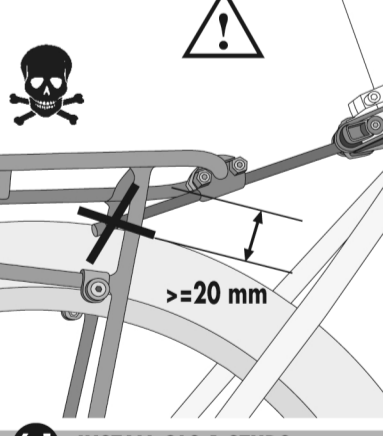

4.3 SHORTEN ROD (IF NECESSARY)

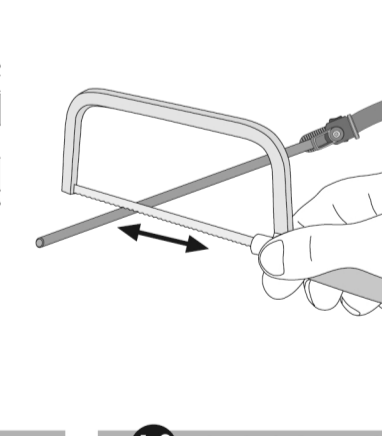

4.4 SECURE ROD CORRECTLY

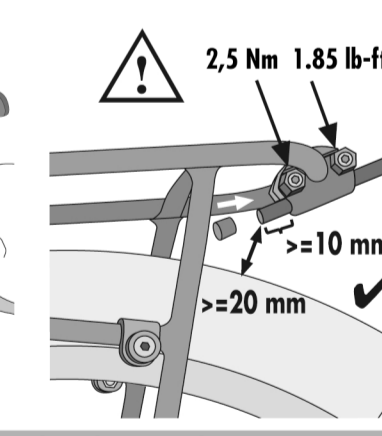

5.1 INSTALL REAR LIGHT ADAPTER

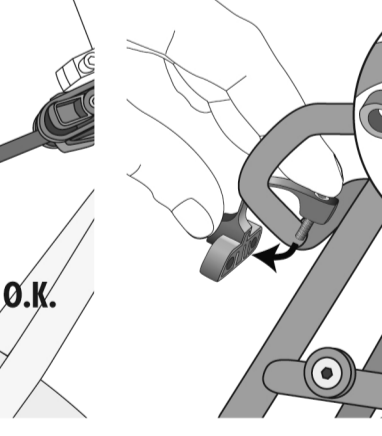

6.1 INSTALL QL3.1 STUDS

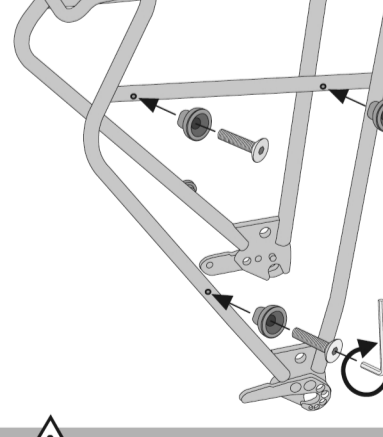

6.2 CHECK SECURE MOUNTING BEFORE RIDING

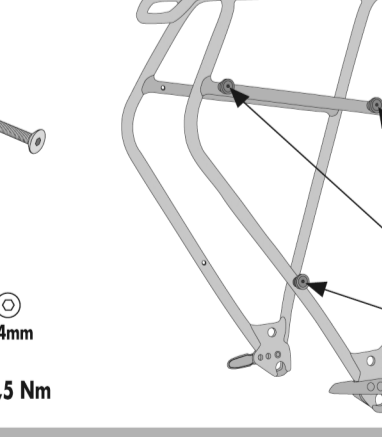

- 1.) 100 km (60 Miles)
- 2.) 500 km (300 Miles)
- 3.) 1000 km (600 Miles)
- 4.) 1500 km (900 Miles)
- etc.

! CHECK FIXATION BEFORE EVERY RIDE

- 1.) 100 km (60 Miles)
- 2.) 500 km (300 Miles)
- 3.) 1000 km (600 Miles)
- 4.) 1500 km (900 Miles)
- etc.

! X = NO



! X = NO



! X = NO

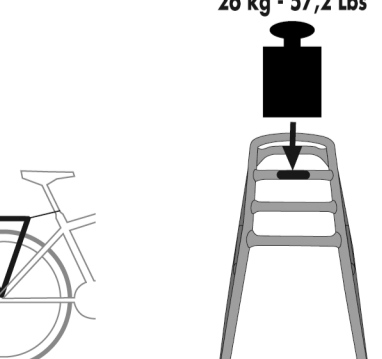

! X = NO

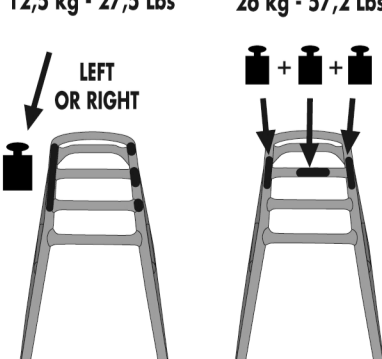

! TEST !

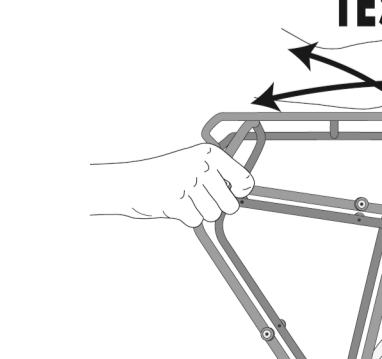

ACCESSORIES

